

WINEGARD® AIR™ 360+

OMNIDIRECTIONAL TV/FM ANTENNA
+ WIFI EXTENDER + 4G ROUTER*

*WiFi & 4G functionality requires Winegard® Gateway™ (GW-1000) sold separately

Model AR2-V2S



Plus!
Internet ready
Requires Winegard
Gateway Router

Create an account to register your product at
winegard.com/register

winegard.com/air-360-plus
Manuel disponible en français au www.winegard.com



2452463



2452463 Rev14-21

Welcome

Thank you for purchasing the Winegard® Air™ 360+ and trusting Winegard to bring connectivity solutions to you while on the go. This product, combined with the Winegard® Gateway™ will provide you more freedom when choosing where to adventure, all while bringing the comforts of TV and secure internet to you and your devices.

Before installing or operating please read these instructions completely and carefully. Failure to follow these instructions could cause damage to the product and/or RV.

If you have any questions or need help, email help@winegard.com or call 1-800-320-9992.

Contents

Welcome	1
Contents.....	1
Specifications/Features.....	2
Parts Included	2
Product Information.....	3
Installation Instructions	3
Power Supply Installation - TV Antenna.....	6
Power Supply Installation - Gateway	7
TV Antenna Operation	8
Troubleshooting.....	9
Warranty Statement.....	11

Disclaimer

Although every effort has been made to ensure that the information in this manual is correct and complete, no company shall be held liable for any errors or omissions in this manual. Changes and technological advances are continuously being made in the over-the-air and wireless market. Information provided in this manual was accurate at time of printing. If the Winegard Air 360+ or Gateway do not function as expected, please contact Winegard Company at 1-800-320-9992, email help@winegard.com, or visit our website at www.winegard.com.

Specifications/Features

- Designed for RV use
 - Durable UV and weather resistant
 - 360° signal reception
 - High definition VHF/UHF digital signals
 - ATSC 3.0 ready
 - Amplified
 - State of the art pHEMT technology with 4G LTE filter
 - Range – up to 55 miles*
 - Height – 7.73"
 - Diameter of dome – 17.25"
 - Frequency range:
 - VHF 54 to 216 MHz
 - UHF 470 to 700 MHz
 - FM 87.5-108 MHz
 - Gain – 18 dB
 - Noise – 1 dB
 - Impedance – 75 ohms
 - Power supply – DC 12 V
 - (1) WiFi antenna**
 - (2) LTE antennas**
- ** For use with the Winegard Gateway

*Antenna mileage figures based on average terrain. Actual receiving distance will vary based on transmitting power, transmitting antenna tower height, global pattern of transmitter, height of receiving antenna, weather conditions, and terrain between receiving path including trees, buildings, hills, mountains, etc.



Parts Included

Tools needed for installing (not included) – butyl tape, scissors, hole saw, drill, Phillips screwdriver, crimping tool, 18AWG power wire, wire strippers.



Product Information

The Winegard Air 360+ system will bring in high definition, local, over-the-air broadcast television, once installed, but has also been designed with the ability to work with the Winegard Gateway as a WiFi extender and 4G LTE router. It is not intended to work with any other router system.

The Air 360+ is designed for RVs with a roof-radius of 230 inches to flat and with a maximum 7-inch roof thickness.

The Air 360+ allows the Winegard Gateway™ to be installed directly below it on the ceiling of the RV.

The Air 360+ can replace another TV antenna and can utilize the coax cable that has already been installed. If doing this, you must ensure the coax runs to the Winegard antenna wall plate/power supply and, if the Winegard Gateway is to be installed, that the power cable is routed to the Gateway wall plate/power supply.

The Air 360+ must be installed first before attempting to install the Gateway™. Before installing verify the following:

- The Gateway can be installed on the RV ceiling directly under the Air 360+.
- Three WiFi/4G antenna cables from the Air 360+ must be able to reach the connection points on the Gateway router.
- +12 VDC must be present where the Gateway will be installed.

Installation Instructions

Figure 1

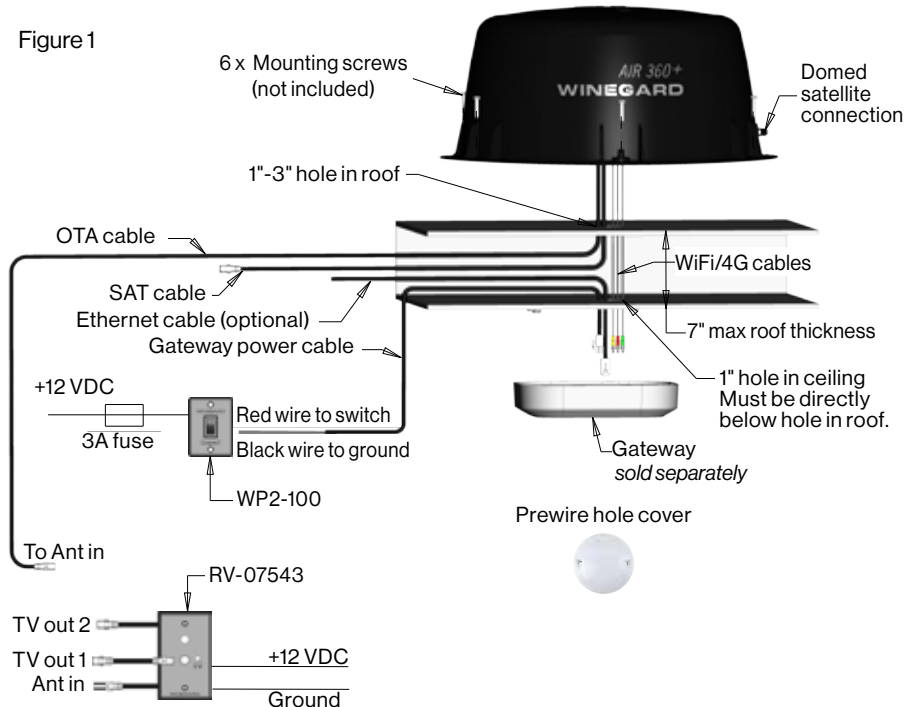

Safety Recommendations

Do not attempt to install this system in the rain or under any wet conditions.
Do not paint this antenna. Painting the antenna will void the warranty.

Before mounting the antenna, determine locations for both the TV antenna wall plate/power supply and Gateway wall plate/power supply. Keep in mind the following:

- Coaxial cables will have to run from the HDTV wall plate/power supply to the antenna and from the wall plate to each television.
- If using the Air 360+ to receive FM stations, an additional coax cable (not provided) will have to run from the wall plate (TV OUT 1 or 2) to the coax to audio cable (provided) and into the radio.
- Coax cables will have to be routed through the roof directly under the perimeter of the antenna. It will not seal correctly for the cables to exit under the flange. Failure to install correctly could cause damage to the antenna and possibly the RV.
- A 12 V connection must be made to the back of both power supplies.
- The Winegard Gateway can always be installed later, however it is recommended to run the power cable to the intended mounting location of the Gateway router.

Choose a location for the antenna that meets the following requirements:

- Offers enough support for a secure installation
- Maintains adequate clearance from the edge of the roof and any obstructions:
 - clearance distance of 24 inches needed from center of antenna to front of the vehicle.
 - clearance distance of 18 inches needed from center of antenna to nearest obstruction and to the edge of the roof.

Obstructions can reduce the antenna's overall performance.

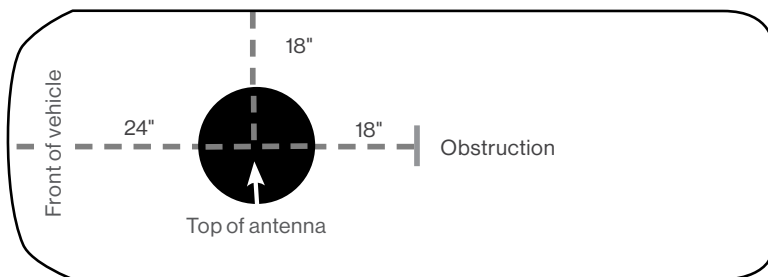
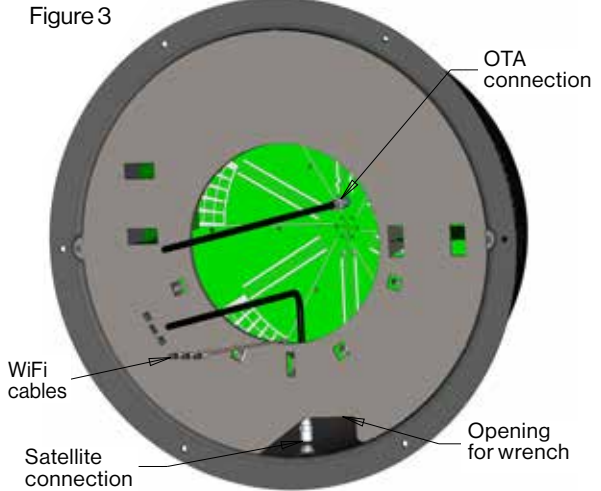

Figure 2

Tools needed for installing (not included) – butyl tape, scissors, hole saw, drill, Phillips screwdriver, crimping tool, 18AWG power wire, wire strippers

Step 1 – After selecting a spot on the vehicle for the antenna, drill a 1–3 inch hole in the roof (DO NOT seal this hole) and directly below drill a 1-inch hole in the ceiling of the RV.

The ceiling hole must not be greater than 1 inch. Otherwise, the prewire hole cover will not install.



Step 2 – Next, connect the provided 20' coax cable to the over-the-air (OTA) connection under the dome. If replacing an existing antenna, connect the coax cable that is already installed to the OTA connection under the dome. Ensure that the connection is finger tight. Connect another coax cable (*not provided*) to the domed satellite connection inside the dome. Use a wrench to tighten the connection in the opening provided (figure 3). Feed both coax cables in the hole of the roof and route to the correct location of either the TV wall plate/power supply (OTA coax) and satellite receiver location (satellite coax).

Step 3 – Feed the other 3 cables (WiFi and 4G) down into the roof hole and through the ceiling of the RV. While ensuring the cables stay in the hole of the RV, position the dome so that the domed satellite connection is facing the rear of the vehicle (figure 4). Satellite bulkhead must face rear of RV.



Step 4 – It is recommended to use butyl tape (not provided) for extra protection under the entire flange before screwing to the roof. Screw 6 approved mounting screws* into the 6 mounting holes around the flange and into the roof.

***Note:** Before installing check with the vehicle manufacturer on approved screws.

CAUTION: Do not overtighten the mounting screws. This could cause the plastic flange to break.

Step 5 – Add approved sealant (check with RV manufacturer) completely around the flanged base and over each screw.

> If planning to install the Winegard Gateway now or at a later time:

Step 6 – Run the 10' Gateway power cable from the hole where the three antenna cables (yellow, green, and red) enter the ceiling of the RV to the predetermined location of the Gateway wall plate/power supply. The white connector of this power cable should be at the same location as the yellow, green, and red connectors. The Winegard Gateway will use this power cable. The bare wires of this power cable should be routed to where the Gateway power switch will be installed.

Step 7 – (OPTIONAL) An ethernet cable can be run to the Gateway if hooking to directly to an ethernet-enabled device such as a smart TV. This will provide better speed, lower latency, and a more reliable connection.

> **If installing the Winegard Gateway now, please review the Winegard Gateway installation manual followed by reviewing the Power Supply Installation on pages 6 and 7 of this manual.**

> **If installing the Gateway at a later time continue to Step 8.**

Step 8 – Lastly, zip tie the prewire power cable along with the 4G LTE and WiFi cables to the notch on the backside of the white prewire hole cover. Cut the excess length of the zip tie off and make sure all the cables are tucked inside the ceiling before screwing the white prewire hole cover to the ceiling with the 2 provided screws.

Power Supply Installation – TV Antenna

WARNING: The power supply should be turned off when connecting cables.

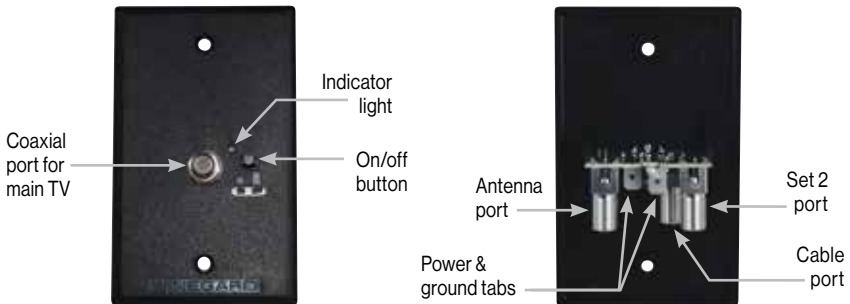

Step 1 – The power supply may be flush mounted in most standard electrical boxes. To flush mount, cut a hole in the wall to fit the box. Run two #12 wires between the wall plate and +12 VDC source, and route download cable to this location.

Step 2 – Make a 12 volt connection from the RV to the power supply. Install the supplied terminals on wires from +12 VDC source, and crimp the terminals with an appropriate crimping tool.

Step 3 – Push the wires onto tabs on the back of the power supply. (“PWR” and “GND” are also noted on the underside of the power supply electronics board).

Step 4 – Connect the coax cable from the antenna to the “ANTENNA” port on the power supply, and tighten until fingertight. Then, tighten ¼ turn more.

Power Supply Installation – TV Antenna continued

Step 5 – If hooking up the antenna to two televisions, connect a coax cable from the “SET 2” port to the “Antenna In” port on the second television.

If hooking up a cable input, connect the cable input to the “CABLE” port on the power supply.

Step 6 – Mount the power supply in wall with the provided screws.

Step 7 – Connect a coax cable from the coax port on the front of the power supply to the “Antenna In” coax port on the main TV.

Step 8 – Press the “ON” switch on the front of the power supply, and check that the wall plate indicator light is on.

This unit is equipped with a polyswitch, which will shut down +12 VDC if there is a direct short between the antenna and power supply. The indicator light will not light. Once the short is eliminated, the device will reset itself.

Power Supply Installation – Gateway

GW-1000

The Winegard Gateway is compatible with the Winegard Air 360+ ONLY. It is the accompanying piece to take your Air 360+ to the next level in connectivity. For more information please visit winegard.com to find a dealer in your area.

Step 1 – Choose a location to install the supplied Gateway wall plate with power On/ Off switch. When selecting a location, remember that a +12 VDC power cable (10' provided) will need to be run from the Gateway to the switch.

Step 2 – For a wall or panel mount, drill or use a hole saw to create a 1¼" hole. Pull the Gateway's power cable and the RV's power wire through the wall or panel.

Step 3 – Be sure the switch is in the OFF position before continuing. Slide the power switch into the wall plate.

Step 4 – Connect the +12 V power wire from the vehicle to a small red terminal insulator. Crimp the connector.

Step 5 – Connect this small red terminal insulator to the edge spade of the power switch.

Step 6 – Connect the red wire from the Gateway's power cable to the other small red terminal insulator. Crimp the connector.

Step 7 – Connect this small red terminal insulator to the middle spade on the switch.

Step 8 – Slide the ground wire from the vehicle into one end of the barrel crimp splice, and slide the black ground wire from the Gateway's power cable into the opposite end of the splice. Crimp the splice.

Step 9 – Mount the wall plate to the wall or panel with the 2 supplied wall plate screws.



On/off rocker switch (shown in OFF Position)

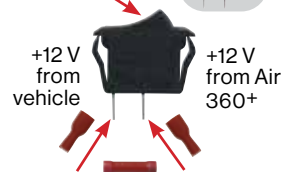

Barrel crimp splice



Power switch into wall plate

TV Antenna Operation



Scan.

Perform Channel Scan:
Select Menu, then
Channel Search



Watch.

Scan monthly
for programming
updates.

First time users must run a channel scan to receive maximum programming.

Ensure the antenna power supply (wall plate) is in the “ON” position and the green indicator light is illuminated.

A new scan will find any new channels that have been added in your area as well as finding any channels that have changed or moved since the last scan.

While the steps to perform a channel scan may vary between televisions or compatible devices, here are some general guidelines to follow.

- Using the television remote, select “Menu” and then “Settings.”
- Select “Channel Setup.”
- Select “Antenna” or “Air,” depending on your TV. Make sure you are not on “Cable.”
- Select “Channel Search” or “Channel Scan.”
Keep in mind that steps to perform a channel scan may vary. If the wording in your TV differs from the options shown, refer to your TV user manual for help.

Running a channel scan is NOT the same as pressing Channel UP/DOWN on your remote.

To receive maximum programming, you have to run a channel scan after setting up the antenna. To keep your channel line-up up-to-date, it is a good idea to run a channel scan monthly, anytime a channel is lost, and anytime you change locations.

Power indicator light is green when power is on.



Power button

Note: Refer to Gateway manual for operation instructions.

Troubleshooting

WARNING: Do NOT install couplers, splitters, etc. between the power supply and the antenna. Installation of any item on the downlead may cause a short in the system. The downlead supplies +12 VDC to the preamp in the antenna.

What to do when your RV/TV antenna is not working properly:

TO TEST SYSTEM –

Step 1 – Make sure TV set is working properly.

Step 2 – Switch power supply ON and OFF watching for difference in picture quality. If there is NO difference, use following steps:

CAUTION: The power supply should be turned OFF when connecting/disconnecting cables to power supply and antenna, but should be turned ON when testing for voltage.

Step 3 – Disconnect cable from antenna and check for +12 VDC at Test Point #1. If there is +12 VDC, the power supply is OK. Replace antenna.

Step 4 – If there is NO +12 VDC at Test Point #1, reconnect cable to antenna. Remove power supply from wall and visually inspect for burned/broken parts. If there are ANY broken/burned parts, replace power supply.

Step 5 – Disconnect cable from antenna jack on power supply. Check for +12 VDC at Test Point #2. If +12 VDC is present, there is a cable problem connecting the power supply to the antenna. Repair/replace cable.

Step 6 – If +12 VDC is not present at Test Point #2, be sure the green indicator light is ON. If not, check the polarity of the red/white wires and the +12 VDC source. If there is still no +12 VDC, replace power supply.

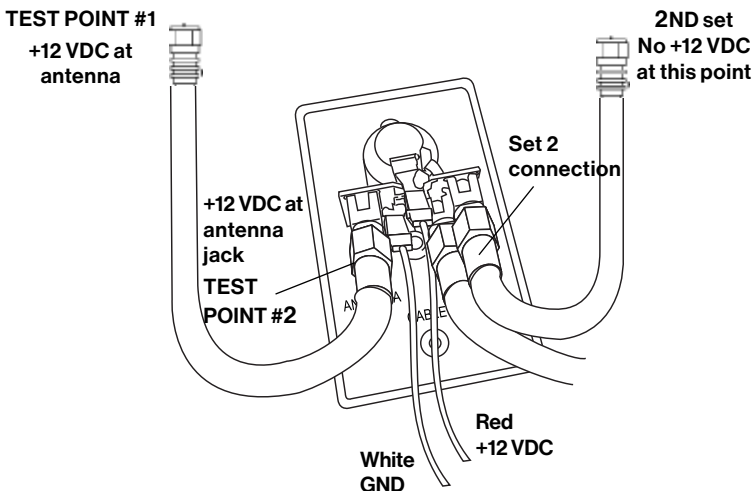

The Winegard Gateway is compatible with the Winegard Air 360+ ONLY. It is the accompanying piece to take your Air 360+ to the next level in connectivity.

- **Upgrade Your Air 360+ to a Live Hotspot for WiFi and 4G LTE** – Easily access WiFi and 4G LTE networks and securely rebroadcast to all of your devices.
- **Maximize Speed & Range** – Stay connected with improved speeds in remote locations where WiFi or cellular options are nonexistent or very weak.
- **GPS Increases Security** – Easily find your RV at a crowded campsite and monitor your RV's IoT from anywhere.
- **Flexible Data Plans with Bring-Your-Own-SIM Option** – Choose between Winegard FreedomGO, AT&T, Verizon Wireless, and T-Mobile.

For more information please visit www.winegard.com/gateway or visit winegard.com/find-a-dealer to find a dealer in your area.



Approved Winegard Satellite Antennas

The satellite antenna connection is recommended for Winegard domed satellite TV antennas. The following satellite products have been tested. Attempting to use with any other satellite may not work.

Installation Requirements:

- The satellite antenna must be installed at a minimum of 6 feet away from the Air 360+.
- Coax with weatherproof connectors should be used when connecting to the satellite F-Jack on the Air 360+.
- If removing a satellite antenna, the factory installed F-Jack cap should be reattached to avoid water intrusion and/or corrosion.
- The Playmaker and Pathway may require the purchase of a Winegard power inserter (Winegard Model PI-GM60) if the coax cable run to the satellite antenna exceeds our recommended length (25').



Air 360+ Model AR2-V2S



Pathway X1, Carryout G2+,
DISH Playmaker, Carryout G3

WINEGARD MOBILE PRODUCTS LIMITED WARRANTY
(2 YEARS PARTS; 1 YEAR LABOR)

Winegard Company warrants this product against defects in materials or workmanship for a period of two (2) years from the date of original purchase. During year one (1) of such warranty, Winegard Company will also pay authorized labor costs to an authorized Winegard dealer to repair or replace defective products. No warranty claim will be honored unless at the time the claim is made, Customer presents proof of purchase to an authorized Winegard dealer (to locate the nearest authorized Winegard dealer, contact Winegard Company, 3000 Kirkwood Street, Burlington, Iowa 52601, Telephone 800-288-8094 or visit www.winegard.com). Customer must provide proof of purchase with a dated sales receipt for the Winegard product to verify the product is under warranty. If the date of purchase cannot be verified, the warranty period shall be considered to begin thirty (30) days after the date of manufacture.

If a defect in material or workmanship is discovered, Customer may take the product to an authorized Winegard dealer for service. Customer must provide proof of purchase to verify the product is under warranty. If the product is brought to an authorized Winegard dealer for service prior to expiration of year one (1) of the warranty period and a defect in material or workmanship is verified by Winegard Technical Services, Winegard Company will cover the Winegard dealer's labor charges for warranty service. The Winegard dealer must contact Winegard Technical Services in advance for pre-approval of the service. Approval of the service is at the sole discretion of Winegard Company.

Alternatively, Customer may ship the product prepaid to Winegard Technical Services (located at 2736 Mt. Pleasant Street, Burlington, Iowa 52601, Telephone 800-788-4417). Customer must return the product along with a brief description of the problem and provide Winegard Technical Services with Customer's name, address, and phone number. Customer must also provide proof of purchase to verify the product is under warranty. If the product is returned before the expiration of the warranty period, Winegard Company will (at its option) either repair or replace the product.

This Limited Warranty does not apply if the product has been damaged, deteriorates, malfunctions or fails from: improper installation, misuse, abuse, neglect, accident, tampering, modification of the product as originally manufactured by Winegard in any manner whatsoever, removing or defacing any serial number, usage not in accordance with product instructions or acts of nature such as damage caused by wind, lightning, ice or corrosive environments such as salt spray and acid rain. This Limited Warranty also does not apply if the product becomes unable to perform its' intended function in any way as a result of the television signal provider making any changes in technology or service.

RETURN AUTHORIZATION POLICY

A Return Material Authorization (RMA) is required prior to returning any product to Winegard Company or Winegard Warranty Services under this warranty policy. Please call our Technical Services Department at 800-788-4417 or send an email to warranty@winegard.com to obtain the RMA number. Please furnish the date of purchase when requesting an RMA number. Enclose the product in a prepaid package and write the RMA number in large, clear letters on the outside of the package. To avoid confusion or misunderstanding, a shipment(s) without an RMA number(s) or an unauthorized return(s) will be refused and returned to Customer freight collect.

WINEGARD COMPANY DOES NOT ASSUME ANY LIABILITIES FOR ANY OTHER WARRANTIES, EXPRESS OR IMPLIED, MADE BY ANY OTHER PERSON.

ALL OTHER WARRANTIES WHETHER EXPRESS, IMPLIED OR STATUTORY INCLUDING WARRANTIES OF FITNESS FOR A PARTICULAR PURPOSE AND MERCHANTABILITY ARE LIMITED TO THE TWO YEAR PERIOD OF THIS WARRANTY.

In states that do not allow limitations on implied warranties, or the exclusion of limitation of incidental or consequential damages, the above limitations or exclusions do not apply.

Some states do not allow limitations on how long an implied warranty lasts, or the exclusion of limitation of incidental or consequential damages, so the above limitations or exclusions may not apply to you.

This warranty gives Customer specific legal rights. Customer may also have other rights that may vary from state to state.

SATELLITE RECEIVER WARRANTY
See manufacturer's limited warranty policy.

WS-MOBWARREV3

2736 Mt. Pleasant Street • Burlington, IA 52601 • 1-800-288-8094 • Fax 319-754-0787 • www.winegard.com

AT&T and the Globe Logo are owned by AT&T Intellectual Property. Verizon Wireless is a trademark of Verizon Trademark Services, LLC. T-Mobile, the magenta color, and the digits design are registered and/or unregistered trademarks of Deutsche Telekom AG. All trademarks, registered trademarks and logos are the property of their respective owners and are not affiliated with Winegard Company. Winegard is a registered trademark of Winegard Company. Printed in U.S.A. ©2021 Winegard Company

Rev1 4-21 2452463