

### ATTACHING COAX FOR HD- MODELS

**STEP 4.** Be sure to unfold tetrapole elements away from boom. Loosen wing nuts on downlead connections. Attach matching transformer ends to the studs between the washers and tighten wing nuts. See Figure 6.

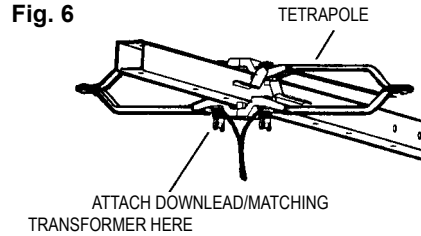

### ATTACHING COAX FOR MODEL HD7210P ONLY

**STEP 4.** Attach the 75 ohm coaxial downlead to the housing. Slide weather boot over the boot collar. See Figure 7.

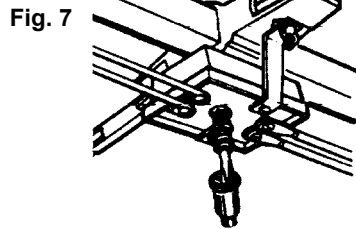

### ATTACHING ANTENNA TO MAST

Loosen U-bolt nuts. Slide U-bolt over mast. Point small end of antenna toward stations and tighten securely. See Figure 8. Install a second U-bolt for antennas with multiple booms. The 75 ohm coaxial cable downlead may be secured to mast by taping or by using plastic wire ties.

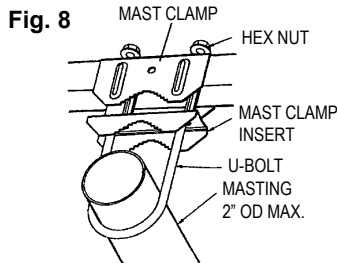

### HOW TO PROVIDE LIGHTNING PROTECTION FOR TV ANTENNA AND SET

**Step 1.** Mount the grounding block as close as possible to where the 75 ohm coaxial cable downlead enters the house. See Figure 9.

**Step 2.** The ground wires for both the mast and the downlead should be copper or aluminum wire, number eight (8) or larger. See Figure 9.

**Step 3.** The downlead wire from the antenna to the grounding block and the mast ground wire should be secured to the house spaced from four (4) to six (6) feet apart. See Figure 9.

**NOTE:** In the case of a "ground up" antenna installation, it may not be necessary to ground the mast if the mast extends four or more feet into the earth. Consult a TV serviceman for the proper depth in your location.

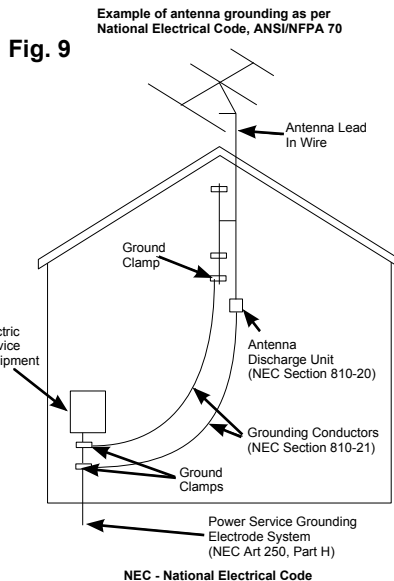

# WINEGARD®

## High Definition (HD) Platinum Antennas

### INSTRUCTIONS

## VHF/UHF MODELS

HD7210P, HD-7010, HD-7015,

## VHF ONLY

### HD-5030 & YAGI SERIES

**WARNING**  
**INSTALLATION OF THIS ANTENNA NEAR POWER LINES IS DANGEROUS. FOR YOUR SAFETY, FOLLOW THE INSTALLATION INSTRUCTIONS.**

### **90 DAY LIMITED WARRANTY**

Winegard Company warrants this Winegard product against any defects in materials or workmanship within 90 (ninety) days from date of purchase. No warranty claim will be honored unless at the time the claim is made, you present proof of purchase to an authorized Winegard dealer (if unknown, please contact Winegard Company, 3000 Kirkwood Street, Burlington, IA 52601-2000, Telephone 800-288-8094).

Winegard Company (at its option) will either repair or replace the defective product at no charge to you. This warranty covers parts, but does not cover any costs incurred in removal, shipping or reinstallation of the product. This limited warranty does not apply if the product is damaged, deteriorates, malfunctions or fails from: misuse, improper installation, abuse, neglect, accident, tampering, modification of the product as originally manufactured by Winegard, usage not in accordance with product instructions or acts of nature such as damage caused by wind, lightning, ice or corrosive environments such as salt spray and acid rain.

The 90 Day Warranty is provided on the condition that the equipment is properly delivered with all handling and freight charges prepaid to your Winegard dealer for return to our factory for repair or replacement. Winegard dealers will arrange for the replacement or repair and return to you without charge the product which failed due to defective material or workmanship.

WINEGARD COMPANY WILL NOT ASSUME ANY LIABILITIES FOR ANY OTHER WARRANTIES, EXPRESS OR IMPLIED, MADE BY ANY OTHER PERSON.

ALL OTHER WARRANTIES WHETHER EXPRESS, IMPLIED OR STATUTORY INCLUDING WARRANTIES OF FITNESS FOR A PARTICULAR PURPOSE AND MERCHANTABILITY ARE LIMITED TO THE 90-DAY PERIOD OF THIS WARRANTY.

The foregoing shall be the sole and exclusive remedy of any person, whether in contract, tort or otherwise, and Winegard shall not be liable for incidental or consequential damage or commercial loss, or from any other loss or damage except as set forth above.

Some states do not allow limitations on how long an implied warranty lasts, or the exclusion of limitation of incidental or consequential damages, so the above limitations or exclusions may not apply to you.

This warranty gives you specific legal rights and you may also have other rights which vary from state to state.

Rev. 2/08

**FOR MODELS WITH REFLECTOR BOOMS INSTALLED IN FACTORY**

**STEP 1.** Remove antenna from carton and unfold elements on reflector booms until they lock into place. See Figure 1.

**STEP 2.** Unfold reflector booms until they lock into place. See Figure 1.

Fig. 1

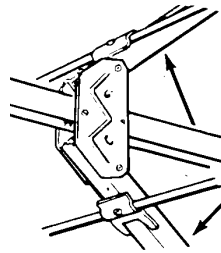

**FOR ALL MODELS**

**STEP 3.** Unfold all other elements until they lock into place. Be sure the elements are locked into position and are flat and parallel to each other. See Figure 2.

Fig. 2

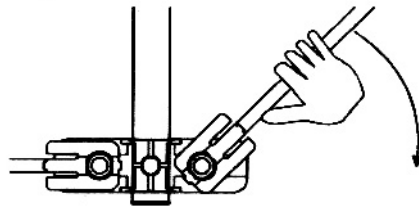

**FOR TWO-PIECE BOOM MODELS**

Remove nut and bolt from boom and slide narrow end of boom into end of larger section aligning bolt holes. Make sure elements of both booms are on top. See Figure 3. Reinstall bolt and nut, being sure to tighten securely.

Fig. 3

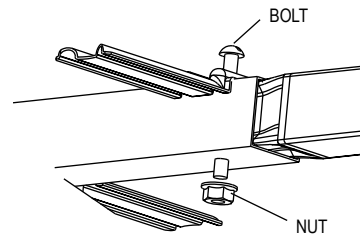

**FOR MODELS WITH BOOM BRACES**

**STEP 1.** Assemble antenna using previous steps. Lay boom brace on top of antenna with U-bolts on same side. Find the bolt hole in the corner reflector and attach brace with the bolt and nut provided. Swing boom brace down toward the rear. Form a "V" with the metal straps. Bolt the "V" to each side of boom. See Figures 4 and 4A.

Fig. 4

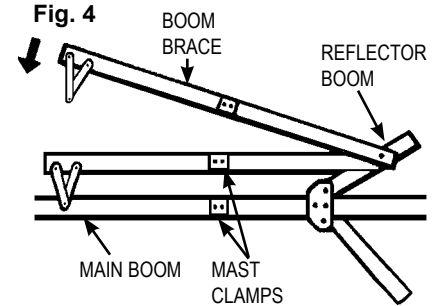
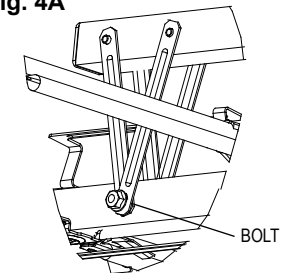

Fig. 4A



**YA- MODELS ONLY**

**ATTACHING COAX FOR YAGI MODELS**

**STEP 4.** Attach cartridge housing bottom to cartridge housing top already attached to antenna by aligning tabs and snapping into place. See Figure 5.

Fig. 5

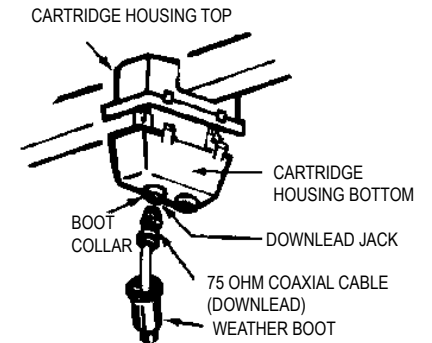

**STEP 5.** Slide weatherproof boot onto coaxial cable and install connector. Attach cable to downlead connection. Slide boot over connector and boot collar.